

### MOUTING ADVICE FOR BUTTERFLY VALVES SERIES G - PMG



**THE BURACCO GUARANTEE CAN ONLY BE ENGAGED FOR VALVES  
WITH HANDLE OR EQUIPPED WITH ACTUATORS  
ASSEMBLED IN OUR SHOP;**

*In the case of motorization by the customer, the only actuators  
authorize are the ones having had the "DEPOT NF"*

- 1) It is forbidden to do welding operations or to treat up near monted valve.
- 2) During the monting between flanges let the butterfly half-open  
It never has to go over each side of the body thickness.
- 3) The tightness guarantee can only be obtain by lightenning the metal/metal contact between the valve and the mating flanges.
- 4) For a good mechanical behavious of the seat it is recommended to use mating flanges which internal diameter is included between the dimensions C and B1 of the below table.

**DO NOT USE ROTATING FLANGE  
COLLET EMBOSSED**

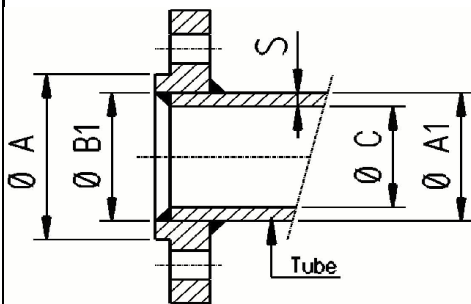

**FLANGE TYPE 01**

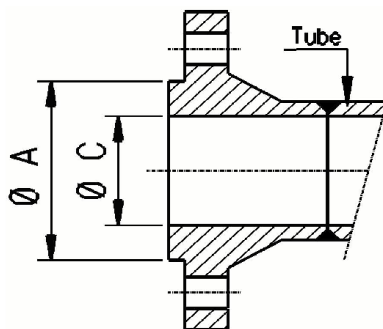

**FLANGE TYPE 11**

FLANGE TYPE 01 PN10-16							PN10				
ND	32-40	50	65	80	100	125	150	200	250	300	350
A	88,0	102,0	122,0	133,0	158,0	184,0	212,0	268,0	320,0	370,0	430
B1	49,0	61,5	77,5	90,5	116,0	141,5	170,5	222,0	276,5	327,5	359,5
A1	48,3	60,3	76,1	88,9	114,3	139,7	168,3	219,1	273,0	323,9	355,6
S	2,6	2,9	2,9	3,2	3,6	4,0	4,5	5,6	6,3	7,1	7,1
C	43,1	54,5	70,3	82,5	107,1	131,7	159,3	207,4	260,9	309,7	341,4

FLANGE TYPE 01 ASA 150											
ND	32-40	50	65	80	100	125	150	200	250	300	350
A	63,5 73	92,1	104,8	127,0	157,2	185,7	215,9	269,9	323,8	381,0	412,8
B1	43,2 49,5	62,0	77,8 74,7	90,7	116,1	142,2 143,8	170,7	221,5	276,4	327,2	359,2
A1	42,4 48,3	60,3	76,1 73	88,9	114,3	139,7 141,3	168,3	219,1	273,0	323,9	355,6
S	3,6	4,0	4,5	5,0	5,6	6,3	7,1	8,0	8,8	10,0	11,0
C	35,2 41,1	52,3	67,1 64	78,9	103,1	127,1 128,7	154,1	203,1	255,4	303,9	333,6

FLANGE TYPE 11 PN10-16							PN10				
ND	32-40	50	65	80	100	125	150	200	250	300	350
A	88,0	102,0	122,0	133,0	158,0	184,0	212,0	268,0	320,0	370,0	430,0
C	43,1	54,5	70,3	82,5	107,1	131,7	159,3	207,4	260,9	309,7	341,4

FLANGETYPE 11 ASA 150											
ND	32-40	50	65	80	100	125	150	200	250	300	350
A	63,5 73	92,1	104,8	127,0	157,2	185,7	215,9	269,9	323,8	381,0	412,8
C	35,2 41,1	52,3	64 67,1	78,9	103,1	127,1 128,7	154,1	203,1	255,4	303,9	333,6

*document non contractuel*